

2 Channel (1-Remote and 1-Local), High Accuracy Temperature Sensor

1 Features

- Temperature range: $-55^{\circ}\text{C} \sim +150^{\circ}\text{C}$
- Typical accuracy: $\pm 0.5^{\circ}\text{C}$
- High resolution: $0.0625^{\circ}\text{C} / 12\text{bits}$
- Conversion time per channel: 16ms
- Digital output:
 - SMBus, I²C interface compatibility
- Supply voltage range: 2.7V ~ 5.5V
- Low quiescent current: (3.3V, 27°C)
 - Average current: $16\mu\text{A} (0.0625\text{Hz}) / 45\mu\text{A} (1\text{Hz}) / 90\mu\text{A} (4\text{Hz})$
 - Local Channel: $180\mu\text{A}$
 - Remote Channel: $380\mu\text{A}$
 - Shutdown current: $0.4\mu\text{A}$
- Series Resistance Cancellation, Automatic Beta Compensation, η -Factor Correction
- Package Information:

Part Number	Package	Body Size (mm ²)
GXTR3012xU	MSOP8L	3.00 × 3.00
GXTR3012xD	DFN8L	2.00 × 3.00

2 Applications

- MCU, GPU, FPGA, DSP, CPU
- Servers, Desktops, and Notebooks
- Industrial and Medical Equipment

3 Description

GXTR3012 is a high-precision, low-power digital temperature sensor compatible with SMBus and I²C interfaces. One remote diode-connected temperature zones can be monitored simultaneously in addition to the local temperature. GXTR3012 features series resistance cancellation, pro-programmable η factor correction, β value detection and automatic compensation, and programmable temperature thresholds, providing a reliable temperature monitoring solution with high accuracy and low power consumption.

GXTR3012 is especially suitable for temperature measurement using remote transistors (NPN / PNP Type) in servers and processors integrated in advanced processes. GXTR3012 supports automatic compensation of transistor-connected PNP ($0.09 < \beta < 21.36$) to achieve high-precision temperature measurement.

The typical accuracy of GXTR3012's local and remote channel is $\pm 0.5^{\circ}\text{C}$. GXTR3012 provide a measurement resolution of 0.0625°C and a measurement range of $-55^{\circ}\text{C} \sim 150^{\circ}\text{C}$. GXTR3012 are available in 3.0mm×3.0mm, 8 pin MSOP and 2.0mm×3.0mm, 8 pin DFN packages.

Figure 1 Typical Application Schematics

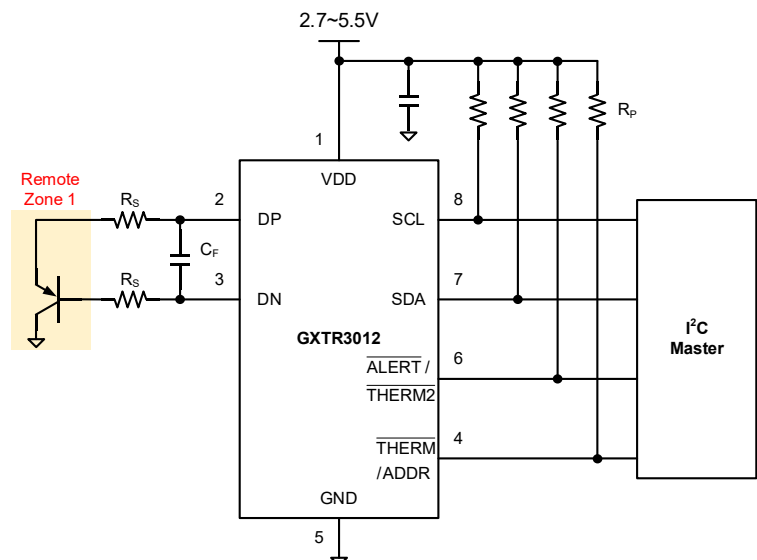

10 Ordering Information

Order Number	Chip Model	Package	SPQ	Note
GXTR3012AU-T&R	GXTR3012AU	MSOP8L	3000	Tape & Reel
GXTR3012BU-T&R	GXTR3012BU	MSOP8L	3000	Tape & Reel
GXTR3012CU-T&R	GXTR3012CU	MSOP8L	3000	Tape & Reel
GXTR3012AD-T&R	GXTR3012AD	DFN8L	3000	Tape & Reel
GXTR3012BD-T&R	GXTR3012BD	DFN8L	3000	Tape & Reel
GXTR3012CD-T&R	GXTR3012CD	DFN8L	3000	Tape & Reel